



P.O. Box 6870, Santa Barbara, CA 93160
 USA 805-562-9120
 www.cmcrescue.com

STAINLESS STEEL CARABINER

Benefits

- Most corrosion-resistant carabiner available
- Great for use in harsh environments
- Key-lock design prevents snagging
- Full 1 inch gate opening on non-ANSI version fits over most litter rails
- Auto-locking gate is easy to use with one hand

Features

- **100% stainless steel**, including internal parts
- **General Use rated** - the only all stainless carabiner available with the highest NFPA rating
- **ANSI Z359.12** certified version
- **Auto-lock gate** for maximum security
- **100% proof load** tested at factory

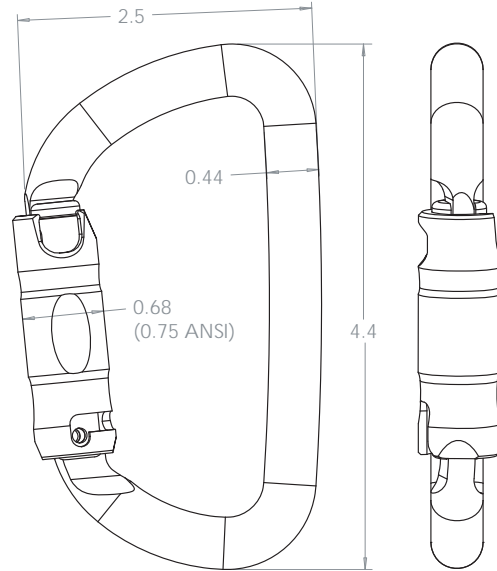

NFPA 1983 Carabiner

Performance Requirements, General Use

- Major axis 3 σ MBS: 40 kN (8,992 lbf.)
- Major axis 3 σ MBS, gate open: 11 kN (2,473 lbf.)
- Minor axis 3 σ MBS: 11 kN (2,473 lbf.)

Item #	300010	300011
Gate Type	Auto-Lock	Auto-Lock
NFPA Rating	General Use	General Use
ANSI Rating	N/A	Z359.12 - 2009
3 σ MBS: Major axis	44 kN (9,891 lbf.)	44 kN (9,891 lbf.)
3 σ MBS: Major axis, gate open	12 kN (2,698 lbf.)	12 kN (2,698 lbf.)
3 σ MBS: Minor axis	16 kN (3,597 lbf.)	16 kN (3,597 lbf.)
Gate Opening	1.05 in. (27 mm)	0.9 in. (23 mm)
Interior Length	3.6 in. (91 mm)	3.6 in. (91 mm)
Weight	7.8 oz. (222 g)	8.4 oz. (241 g)